

Transformation of eLearning to Integrated and Sharable E-Education System

Bundit Manoonkulachai

Product Manager (Education Solution)
Samart Telcoms Public Co., Ltd.
Thailand
E-mail: bunditm@samtel.com

It has been a quest of mankind to inherit it's wisdom from generation to generation. Far back to the past, a miracle man, teaching young generation to respect the power of the nature, was telling a story earth, water, wind, and fire. He pointed to a red line on cave wall. The line was telling there were men running toward a cave and behind them was a tumbling wind. The miracle man seemed to be a principal of the tribe who was using a blackboard, cave wall, inside a classroom, cave, to teach his students.

It is an effective teaching methodology, which has been carried out for centuries. It is a never-ending story for mankind to search for the most effective way to educate. New equipment has been invented. It was started from cave wall to blackboard, caves to classrooms, leather sheets to books, calculators to computers. No matter how they are changed, they are still vehicles for mankind to begin a new quest to reach a higher level of wisdom.

Today a new journey has begun. The latest vehicle, eLearning, has been invented as a brighter star that will be shining in every corner of the world. It is beyond imagination of the miracle man to dream of sending his spell through out the world. However, eLearning, creates this magic.

Basically, eLearning system relies on three components, software, hardware, and connection. It began with connecting computers and servers inside an organization as intranet and used CAI (Computer Aid Instruction) as content software. Once the Internet has emerged, it was adapted to WBI (Web Base Instruction) and others. When people talk about eLearning software, they usually think of LMS (Learning Management System). Mostly, it requires three servers to handle its transactions. The first sever is used for running application. The second sever is used for streaming media such as video files, voice files, and animation files which are stored in the third sever. The third sever is used as database sever to store courseware.

In the very beginning, the LMS system was introduced to an organization as a single sever or computer which does all three function, running application, streaming media, and storing courseware and used LMS as eLearning software. Every client, PC, was connected to this sever to request information such as LMS admin transaction, streaming video, and viewing courseware. When requested information is overwhelming, the server becomes overloaded. Then, the system is risky to be collapsed.

Single Sever for LMS

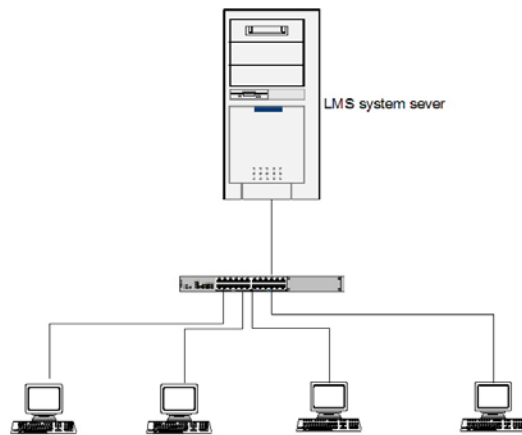

For schools and universities, this model is good for testing in laboratory's scale. Once a single sever becomes overloaded, those three functions, running application, streaming media, have to be separated, and each sever can be expanded to support increasing load, independently.

Expanded LMS System

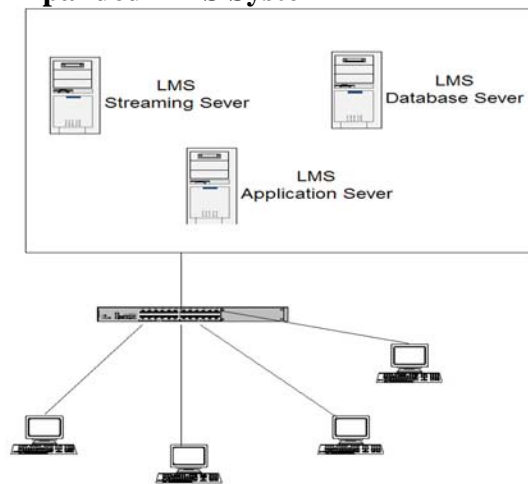

This expanded system was mostly used for intranet. The eLearning was conducted internally via LAN. Once the Internet became popular, a new version of LMS has emerged as web based instruction, which supports internet protocol. Users or student can access the system via Internet. However, This web based model needs fixed line that's always connected to the Internet. There are also some universities which provide internet

connection directly to their students by setting up a system that the student can dialup to the university to get access to the Internet and use some applications hosted inside the university's system. The system is connected to the Internet via a big pipe to the ISP and users or students share it's connection capacity.

Web Based LMS System

Students or users use dialup modem to connect to ISP and use internet browser to open LMS application

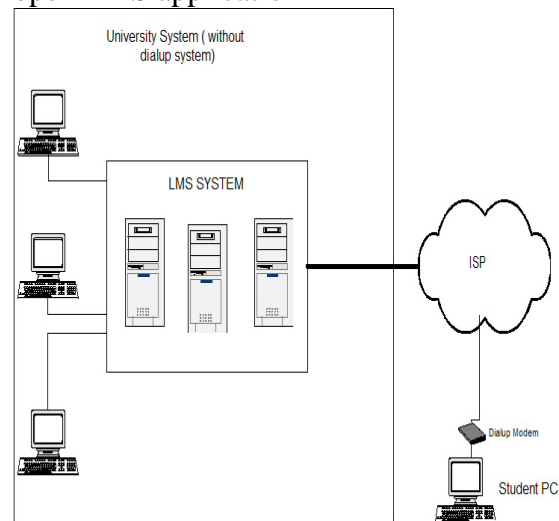

LMS System with Dialup System inside University

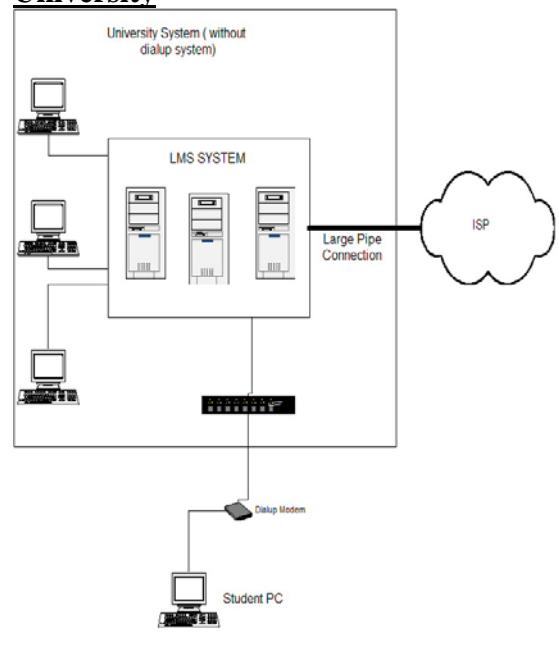

With this model, the university is acting like an ISP where students dial directly to the university to get access to the internet via ISP and browse back to university LMS system. Even if, there are a lot of universities using this model, it has many limitations of implementing eLearning system. Firstly, the university has to keep expanding its system such as dialup system, application servers, and fixed line connection to cope up with dynamic demand from students and users. The expanding cost is so high that it will not meet the economy of scale. Secondly, the university has to establish an ICT team to operate and maintain the system with it is not a university's competency. It's also a burden and costly. Last, students and users will never get ISP's class quality because of infrastructure limitation and many hops of connection that slow down the connection speed.

ELearning System at IDC

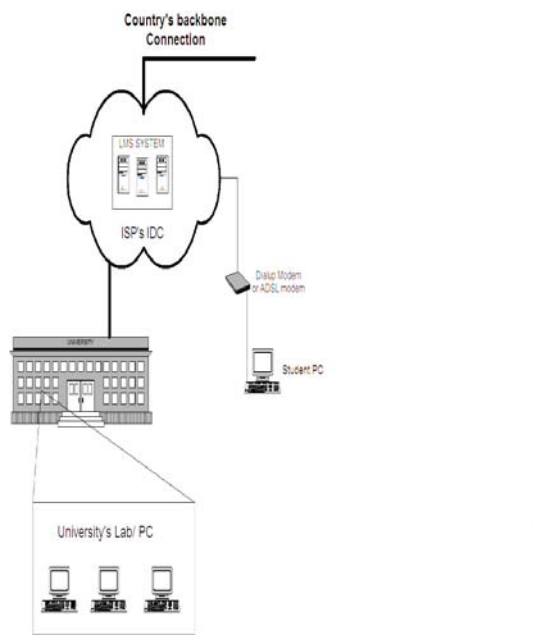

There is an alternative that the university can use other parties' facilities to facilitate its eLearning to maximize system quality at the lowest cost. Furthermore, it can be shared

with other universities as an eLearning center. Instead of setting up a huge system with very high bandwidth connection at university site, the university can use ISP's facility, which normally hook up with nation's backbone internet connection, to set up eLearning system at ISP's IDC. Normally, ISP has invested high quality facility to support its customers; for instance, it has a server farm with security system which connected to very high speed internet from nation's backbone. If ISP wants to increase the bandwidth, it can be done easily at lower cost compared to the university. After having an eLearning system at IDC, the university can connect to its system by using a dedicated line specially used for eLearning. The University is able to establish its internal content database system to synchronize with IDC's system to get maximum performance of implementing eLearning system. We may call this model as hybrid system, integrated system between internet and intranet. Also, at IDC, the eLearning system can be easily shared with other universities by connecting to IDC. As a result, the cost of implementing eLearning system is much lower compared to setting up stand alone system at each university.